



technical datasheet

## MTL660 Displays

Loop-powered indicators for hazardous areas

- Loop powered 4-20mA
- Field and panel mounting
- Environmental protection to IP67
- Easy to configure
- Number of displayed digits configurable
- Backlight options
- Zone 2 mounting



The **MTL661, MTL662, MTL663 and MTL665 digital indicators** enable process variables to be displayed locally in hazardous and general purpose plant areas. A typical example would be the re-transmission of mass/flow computations from the safe area, through a suitable MTL IS interface to the indicator in the hazardous area.

The displays are loop powered from the 4-20mA process signal and their low voltage drop allows them to be installed in almost any 2-wire, 4-20mA transmitter loop.

All units can indicate measured values in a linear or a square root extraction mode; the latter being used, for example, to display flow from differential pressure measurement devices such as orifice plates, Dall tubes, or venturi.

The **MTL661 Field mounting unit is housed in a tough aluminium enclosure**, suitable for wall or pipe mounting. For corrosive atmospheres use the **MTL663** - the plastic case provides excellent resistance to harmful contaminants.

The **MTL665** is the panel mounted version and is IP65, IP66, IP67 and NEMA4 rated.

**MTL66x IS indicators are classified as 'non-energy storing' simple apparatus** so they can be inserted into any IS loop without recertification.

For **Zone 2 mounting**, without the need for an IS barrier or isolator, the MTL661-NA and MTL662-NA are available.

EPS660 RevH 160713

**COOPER** Crouse-Hinds

[www.mtl-inst.com](http://www.mtl-inst.com)

# MTL661, MTL662 & MTL663

## I.S. INDICATORS

loop powered + backlight 'B' option

The MTL66x range offers a variety of field and panel mounting IS indicators to display the current flowing in a 4–20mA loop. The small voltage drop of <1V allows the loop powered display to be installed in almost any 4–20mA loop. The -NA versions permit mounting in Zone 2 without an IS barrier or isolator.

Configuration is carried out using the front panel switches (which can be password protected). Range units, upper and lower limits, decimal point positioning and number of digits displayed are all configured via the front panel.

### SPECIFICATION

#### Unit location

Zone 0, IIC, T4 hazardous area

#### Display

5½ digits - 26mm height (process value)

Eleven 8mm digits (process units & current)

#### Voltage requirements under all conditions

<1V, loop powered

#### Ambient Temperature

Operating: -25°C to +70°C

Storage: -40°C to +80°C

#### Humidity

5-99%RH

#### Input range

4-20mA

#### Over-range

200mA maximum without damage

#### Display Range

-99999 to 199999 (Configurable)

Number of digits after decimal point configurable

#### Zero and span

Setting: anywhere in range

#### Scale direction

Normal or reverse: software selected.

#### Out of range indication

"----- RANGE ERROR" displayed between 3.5 - 3.75mA

"99999 RANGE ERROR" displayed at current >22mA

#### Operating modes

Linear or square root extraction is software selectable.

#### Accuracy at 20°C

± 0.01mA

#### Effects of temperature on accuracy

Zero: ± 0.0025% of span /°C

Span: ± 0.01% of span /°C

#### Ripple rejection

<0.01mA error with 1mA peak to peak ripple at 50Hz

#### Electrical safety

The input circuit of the indicator is designed such that it does not influence the intrinsically safe circuit to which it is connected. (In the USA the application is covered by the entity concept.)

Input circuit (terminals 4 & 5) in type of explosion protection intrinsically safe Ex ia IIC, with the following parameters:

Ui=30V, li=200mA, Pi=1.2W, Ci=0nF, Li=0mH only for connection to a certified intrinsically safe circuit not exceeding these values.

#### Backlight (see Ordering Information & final page for details)

Separately powered backlight from an IS power source

(U<sub>o</sub> = 28V, I<sub>o</sub> = 200mA, P<sub>o</sub> = 0.96W max.)

#### Dimensions

See final page



Showing backlight

### ORDERING INFORMATION

When ordering a MTL661, MTL662 or MTL663, use one of the following order codes to uniquely specify your requirement.

Order code	Type	Backlight	Case material	Weight (nom.)	Case style
MTL661	Field	No	Aluminium	825g	A
MTL661B	Field	Yes	Aluminium	825g	A
MTL661-NA	Field	No	Aluminium	825g	A
MTL661B-NA	Field	Yes	Aluminium	825g	A
MTL662	Panel	No	Aluminium	425g	B
MTL662B	Panel	Yes	Aluminium	425g	B
MTL662-NA	Panel	No	Aluminium	425g	B
MTL662B-NA	Panel	Yes	Aluminium	425g	B
MTL663	Field	No	GRP	500g	A
MTL663B	Field	Yes	GRP	500g	A

The given data is only intended as a product description and should not be regarded as a legal warranty of properties or guarantee. In the interest of further technical developments, we reserve the right to make design changes.



EUROPE (EMEA): +44 (0)1582 723633  
enquiry@mtl-inst.com

THE AMERICAS: +1 800 835 7075  
csinfo@mtl-inst.com

ASIA-PACIFIC: +65 6 645 9888  
sales.mtlsing@cooperindustries.com

EPS660 RevH 160713

# MTL665

## I.S. INDICATOR

loop powered + backlight 'B' option

The MTL665 is a DIN-standard, panel mounting, IS indicator to display the current flowing in a 4–20mA loop. The small voltage drop of <1V allows the loop powered display to be installed in almost any 4–20mA loop.

Configuration is carried out using the front panel switches (which can be password protected). Range units, upper and lower limits, decimal point positioning and number of digits displayed are all configured via the front panel.

### SPECIFICATION

#### Unit location

Zone 0, IIC, T4 hazardous area

#### Display

5½ digits - 26mm height (process value)  
Eleven 8mm digits (process units & current)

#### Voltage requirements under all conditions

<1V, loop powered

#### Ambient Temperature

Operating: -25°C to +70°C  
Storage: -40°C to +80°C

#### Humidity

5-99%RH

#### Input range

4-20mA

#### Over-range

200mA maximum without damage

#### Display Range

-99999 to 199999 (Configurable)  
Number of digits after decimal point configurable

#### Zero and span

Setting: anywhere in range

#### Scale direction

Normal or reverse: software selected.

#### Out of range indication

"----- RANGE ERROR" displayed between 3.5 - 3.75mA  
"99999 RANGE ERROR" displayed at current >22mA

#### Operating modes

Linear or square root extraction is software selectable.

#### Accuracy at 20°C

± 0.01mA

#### Effects of temperature on accuracy

Zero: ± 0.0025% of span /°C  
Span: ± 0.01% of span /°C

#### Ripple rejection

<0.01mA error with 1mA peak to peak ripple at 50Hz

#### Electrical safety

The input circuit of the indicator is designed such that it does not influence the intrinsically safe circuit to which it is connected. (In the USA the application is covered by the entity concept.)  
Input circuit (terminals 4 & 5) in type of explosion protection intrinsically safe Ex ia IIC, with the following parameters:  
Ui=30V, Ii=200mA, Pi=1.2W, Ci=0nF, Li=0mH only for connection to a certified intrinsically safe circuit not exceeding these values.

#### Backlight (see Ordering Information & final page for details)

Separately powered backlight from an IS power source  
(U<sub>O</sub> = 28V, I<sub>O</sub> = 200mA, P<sub>O</sub> = 0.96W max.)

#### Dimensions

See final page



### ORDERING INFORMATION

When ordering a MTL665 use one of the following order codes to uniquely specify your requirement.

Order code	Type	Backlight	Case material	Weight (nom.)	Case style
MTL665	Panel	No	Aluminium	300g	C
MTL665B	Panel	Yes	Aluminium	300g	C

The given data is only intended as a product description and should not be regarded as a legal warranty of properties or guarantee. In the interest of further technical developments, we reserve the right to make design changes.



EUROPE (EMEA): +44 (0)1582 723633  
enquiry@mtl-inst.com

THE AMERICAS: +1 800 835 7075  
csinfo@mtl-inst.com

ASIA-PACIFIC: +65 6 645 9888  
sales.mtlsing@cooperindustries.com

EPS660 RevH 160713

## CASE DIMENSIONS (mm)

### Style 'A'

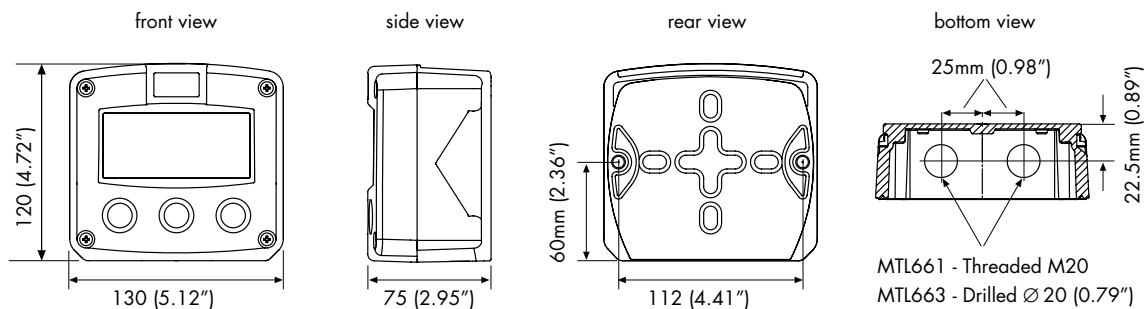

### Style 'B'

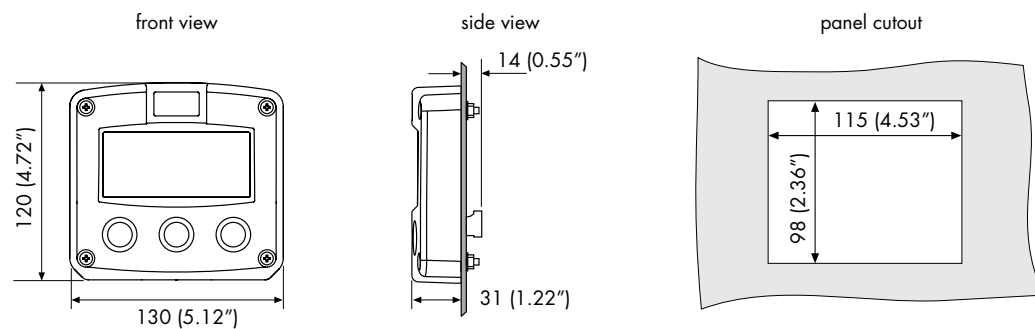

### Style 'C'

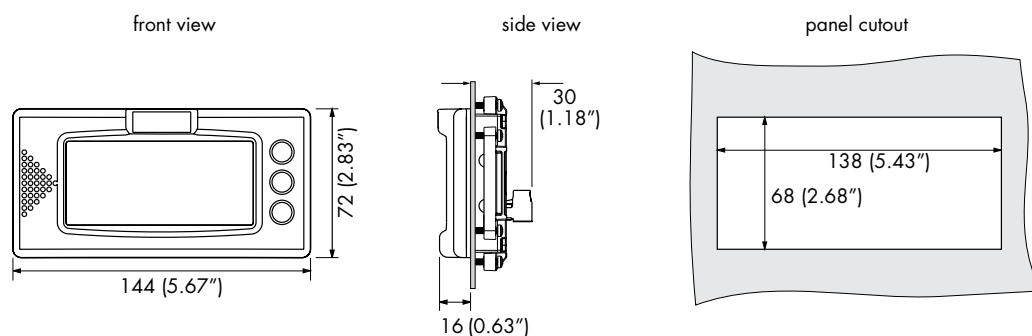

## ACCESSORIES

Order code	Description	Used with
<b>WMP66</b>	Wall mounting plate	MTL661/663
<b>PMA66</b>	Pipe mounting adaptor used with WMP66	MTL661/663
<b>PIP66</b>	Pipe mounting kit	MTL661/663
<b>GAS660</b>	Spare gaskets - pk of 10	MTL661/663
<b>GAS665</b>	Spare gaskets - pk of 10	MTL665

### Recommended IS interfaces for powering display

- **Input circuits (in series with transmitter)**  
MTL5541, MTL4541, MTL7787+
- **Output circuits (direct connected or in series with field device)**  
MTL4546Y, MTL5546Y, MTL7728P+
- **Recommended IS interfaces for powering backlight**  
MTL5521, MTL4521, MTL7728P+





# MTL646/647 DISPLAYS



- ◆ IS display certified to ATEX
- ◆ High contrast LCD with backlight
- ◆ Communication from a safe area via a galvanic isolator
- ◆ Operator push-buttons or external switch inputs
- ◆ Two switch outputs
- ◆ IP65 front panel

The **MTL646/647 Serial Text Displays** are intrinsically safe instruments that can display text and simple graphics in a hazardous area. Having a number of push-buttons and two solid-state switched outputs, they provide a low cost operator interface ideal for simple machine and process control applications. In addition to new installations, the legacy protocol enables existing MTL643/644 display systems to be easily upgraded.

**Data and power** are normally supplied by a 2-wire serial data link from an MTL5051 isolator in the safe area. This isolator, which can power and communicate with up to two MTL646/647 serial text displays, has a bi-directional RS232 or RS422 safe area port. Alternatively, a 3 wire system may be used to communicate with up to four MTL646/647 text displays. The high contrast LCD incorporates a green backlight that is powered by the serial data link. Brightness and contrast are adjustable enabling the display to be read in all lighting conditions from full sunlight to total darkness.

**Six push-buttons** on the front panel of the MTL646 (four on the MTL647) may be used for operator acknowledgments or controls. If larger industrial switches are required, these may be connected to the text display rear (MTL647-internal) terminals. When the remote switches are activated, the front panel push-buttons are disabled automatically.

**Two isolated switch outputs**, which can control certified hazardous area loads such as sounders, lamps and valves, are included.

The **MTL646/647 text displays** are normally controlled and interrogated by a safe area process computer or by a dedicated instrument such as a PLC or weighing system. The text displays may be used singly but up to four instruments can be multidropped on a hazardous area network. At a data rate of 9600 bps, the cable between the safe area galvanic isolator and the MTL646/647 text display may be up to 100m long. The protocol, which uses ASCII characters, enables text to be written anywhere on the screen in five different font sizes, together with lines, boxes and bargraphs. Simple bitmap graphics may be downloaded to the display and all characters can be reversed or flashed. Information can also be written to a hidden screen which may be displayed when required.

**Five different operational modes** are selectable, allowing the user to choose the appropriate level of communications security for each application. These range from immediate execution of a command with no message acknowledgement, to a 16 bit CRC. The communications speed, number of stop bits and polarity of the parity bit can also be defined.

The **legacy protocol** enables the MTL646 or MTL647 to replace an MTL643 or MTL644, in order to provide certification to ATEX and a display backlight. No software or galvanic isolator changes are required and the MTL646 will fit into the existing panel cut-out. If required, simple modifications to the driver software will allow the enhanced features of the MTL646/647 to be used.



## SPECIFICATIONS

### Location

Zone 0, 1 or 2

### DISPLAY

#### Type

120 x 64 pixel liquid crystal.

#### Display Size

86.5mm x 45mm.

#### Backlight

Powered from serial link.

#### Characters

ASCII character set, 5 font sizes each with 4 computer definable soft characters.

#### Hidden screen

May be written to at any time and displayed when required.

#### Switch cable length

5m max.

### OUTPUTS

Two software controlled switch outputs.

#### Contacts

Isolated single pole solid state switch (certified as simple apparatus).

$R_{on}$  less than  $5\Omega + 0.7V$

$R_{off}$  greater than  $1M\Omega$

#### I.S. parameters

$U_i = 28V_{dc}$ ,  $I_i = 200mA$ ,  $P_i = 0.85W$

### DATA

#### Transmission Speed

0.3, 0.6, 1.2, 2.4, 4.8, 9.6 or 19.2k bps.\*

#### Cable length between isolator(s) & MTL646/647

100m max at Baud rate of 9.6k bps\*

\*Depends upon configuration & type of cable - see instruction manual.

#### Format

1 or 2 stop bits; odd, even or no parity bit; 7 or 8 data bits.

#### Protocol

MTL646/647 or MTL643/644.

### CONTROLS

#### Front panel

MTL646: 6 push-buttons which can be software interrogated.

MTL647: 4 push-buttons which can be software interrogated.

Each button function may be displayed on the screen. Buttons may be disabled.

#### External switches

Control may be transferred to six external switches; front panel buttons are inhibited.

### ENVIRONMENTAL

#### Operating temp

-20°C to +60°C (certified for use at -40°C)

#### Humidity

To 95% @ 40°C

#### Enclosure

Front IP65

Rear IP20

### MECHANICAL

#### Terminals

Removable with screw clamp for 0.5 to 1.5mm 2 cable.

#### Weight

MTL646 0.7kg

MTL647 1.6kg

### ACCESSORIES

#### Tag number

Thermally printed strip on rear of instrument.

#### Programming guide

May be downloaded from <http://www.mtl-inst.com>

## APPROVALS

For the latest certification information visit:  
[www.mtl-inst.com/certs\\_1.nsf](http://www.mtl-inst.com/certs_1.nsf)

### MTL646

Country (Authority)	Standard	Certificate/ file no.	Approved for
UK (ITS to CENELEC standards & ATEX Directive)	EN 50020: 2002 EN 50014: 1997 EN 50284: 1999	ITS03ATEX21172	Group II Category 1G EEx ia IIC T5
UK (ITS to CENELEC standard)	EN 50039: 1980	Ex 03E21194 2-wire system Ex 03E21195 3-wire system Ex 03E21196 4-wire system	EEx ia IIC T5
USA (FM)	3610 entity  3611 non-incendive	3026711	Class I, Div 1, Grps A-D Class 1, Zone 0 Group IIC  Class I, Div 2, Grps A-D Class 1, Zone 2 Group IIC

### MTL647

Country (Authority)	Standard	Certificate/ file no.	Approved for
UK (ITS to CENELEC standards & ATEX Directive)	EN 50020: 2002 EN 50014: 1997 EN 50284: 1999	ITS03ATEX21173	Group II Category 1G EEx ia IIC T5
UK (ITS to CENELEC standard)	EN 50039: 1980	Ex 03E21194 2-wire system Ex 03E21195 3-wire system Ex 03E21196 4-wire system	EEx ia IIC T5
USA (FM)	3610 entity  3611 non-incendive	3026711	Class I,II,III, Div 1, Grps A-G Class 1, Zone 0 Group IIC  Class I, Div 2, Grps A-D Class 1, Zone 2 Group IIC  Class II, Div 2, Grps E-G Class III, Div 2



EUROPE (EMEA)  
AMERICAS  
ASIA PACIFIC  
E-mail: [enquiry@mtl-inst.com](mailto:enquiry@mtl-inst.com) Web site: [www.mtl-inst.com](http://www.mtl-inst.com)

Tel: +44 (0)1582 723633  
Tel: +1 603 926 0090  
Tel: +65 487 7887

Fax: +44 (0)1582 422283  
Fax: +1 603 926 1899  
Fax: +65 487 7997

# MTL646

## DIMENSIONS

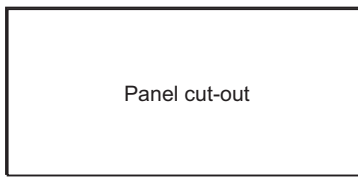

Panel cut-out

**Recommended panel cut-out**  
 DIN 43 700  
 138.0 +1.0/ -0.0 x 68.0 +0.7/ -0.0

To achieve an IP65 seal between the instrument and the panel  
 136.0 +0.5/-0.0 x 66.2 +0.5/-0.0  
 Four panel mounting clips must be used

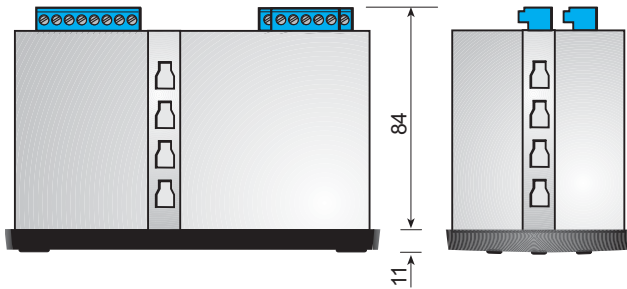

84  
11

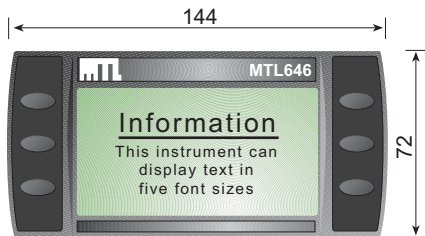

144

72

## TERMINAL CONNECTIONS

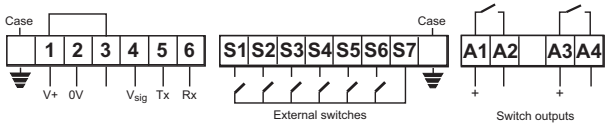

## CONNECTIONS

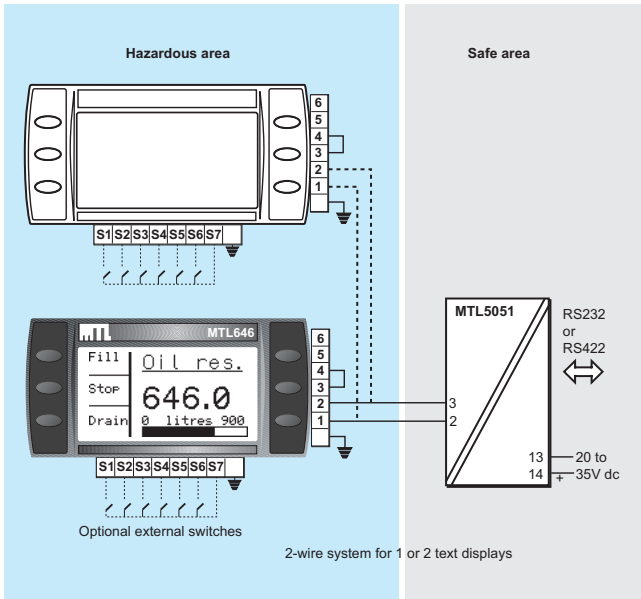

# MTL647

## DIMENSIONS

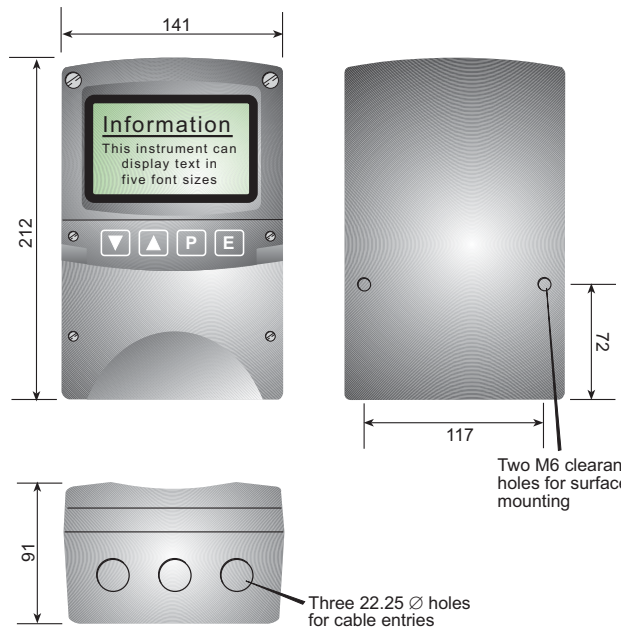

## TERMINAL CONNECTIONS

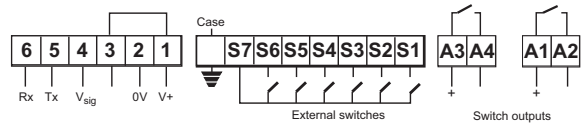

## CONNECTIONS

